

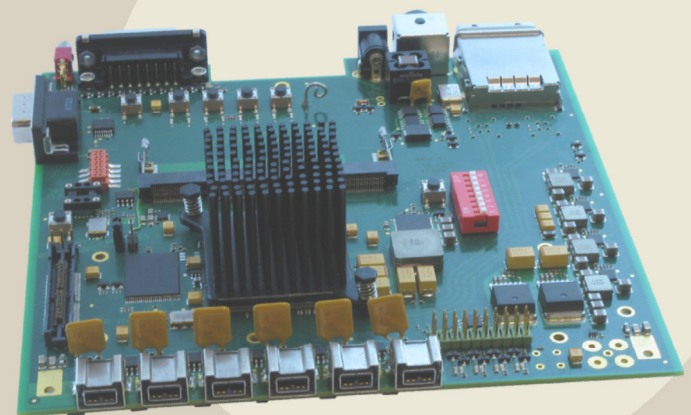

1394 IP SOLUTIONS

FireESDK



PRODUCT OVERVIEW:

In order to foster the market adoption of S3200 DapTechnology has released a dedicated embedded system development kit **FireESDK™**. It is aimed at providing a suitable HW and FW reference platform for rapid embedded systems prototyping of various products with a high speed serial bus interface.

FireESDK™ utilizes the innovative 1394 IP solution FireCore™ (i.e. the combined IP building blocks for LLC IP (FireLink®) and PHY IP (FireGate™) and thus creates a very flexible, customizable and expandable reference platform for any embedded systems design. Therefore the new platform represents a streamlined SOC development platform and allows combining FireCore™ with other embedded systems components (e.g. data compression and encryption mechanisms, onboard data processing, etc)

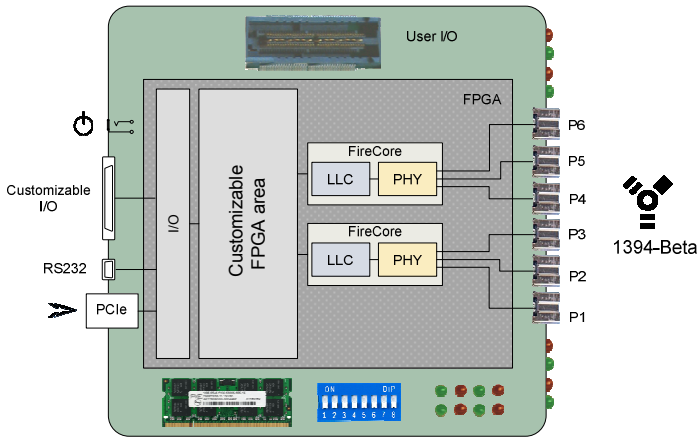

Example of a dual-lane (PHY and LLC) SOC with 3 ports per PHY

DESIGN FEATURES AND BENEFITS:

There are several advantages when using FPGAs to implement a complete 1394 I/O interface. Some of these are:

Single-chip solution: Combination of PHY IP and Link Layer IP thus creating smaller solutions. Additional components can be added to create a System-On-Chip (SOC) solution.

Flexible number of ports: Architecturally the HW support up to 6 PHY ports with flexible routing.

Flexible number of nodes: FireCore can be run multiple times within the FPGA thus creating the design possibility for devices with redundant bus interfaces (essential for deterministic and high reliability systems) or multilane devices for even higher bandwidth requirements.

Optional debug and test features (pending): Optionally, the user can include debug and test features like BERT (Bit Error Rate Test) Low level data monitoring and recording

Field-upgradable: The used FPGAs are field upgradable thus allowing the addition of new features or bug fixes, even if the device is already in the field.

Cost effective ASICS: Once a design is finalized an IP solution offers a cost effective path to rendering a custom ASIC.

HARDWARE PLATFORM:

A special Embedded Systems Design Kit Platform based on the Xilinx Virtex-6 is available. It provides a development environment for embedded system designs that demand high-performance, serial bus connectivity and advanced memory interfacing. The ESDK may be connected to a host computer via the PCI Express interface.

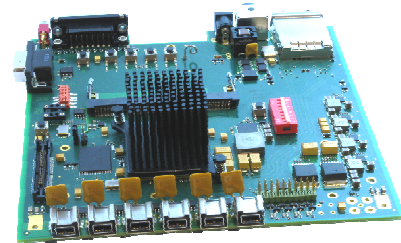

FPGA Device	XC6VLX130T-2FFG1156C
Onboard Memory	1GB DDR2 SO-DIMM (expandable) Configuration FLASH 256MB
1394 PHY / LLC	FireCore (FireGate + FireLink)
Configurable I/Os and indicators	8 DIP switches, 6 pushbuttons, 16 LEDs 76-pin High Speed User IO connector (16 differential I/O, 3 differential clocks, 5 single ended I/O, 3.3V power)
Standard Interfaces	RS232, DB9 connector PCI Express x4 Cable Connector 6x 1394b (Beta) connectors
Package Content	ESDK3200 Development Platform Universal AC/DC Adapter 1394 Cable
PartNumber	ESDK3200

Check directly with DapTechnology for availability of Altera platforms.

CONTACT INFORMATION:

DapTechnology B.V.

Zutphenstraat 67
7575EJ Oldenzaal
the Netherlands
Ph: +31 541 532941
Fax: +31 541 530193
sales@daptechnology.com
www.daptechnology.com

DapUSA, Inc.

780 W San Angelo Street
Gilbert, AZ 85233
United States of America
Ph: (480) 422 1551
Fax: (302) 439 3947
sales@daptechnology.com
www.daptechnology.com