

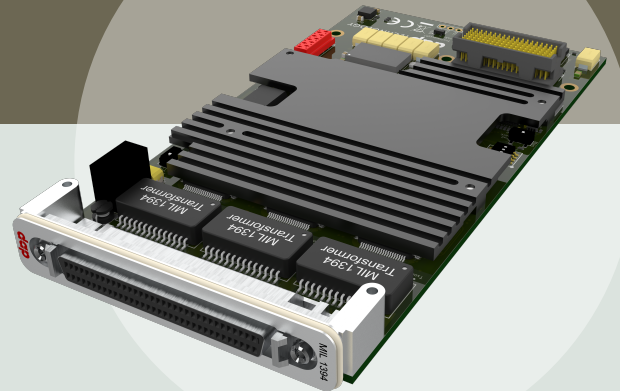

INTERFACE SOLUTIONS

FIRETRAC

3445bT
3845bT



FireTrac® Overview:

The **FireTrac®** product family complements DapTechnology's successful **FireSpy®** and AS5643 OHCI host adapter product lines. It clearly is the next generation SAE AS5643 data processing, simulation and testing solution.

DapTechnology has seen an increasing demand for more streamlined hardware systems for the processing of AS5643 (and generic 1394) data streams. More and more customers get involved in monitoring the actual data content rather than the 1394 layer. And for simulation purposes, they require advanced error insertion capabilities that can only be accomplished with non-off-the-shelf Link Layer implementations. IRIG time-stamping of monitored events on the bus is a typical requirement.

FireTrac® provides a powerful solution for this market need. It is designed to natively (not just as an add-on protocol) support AS5643. Besides the standard IEEE1394 features, **FireTrac®** has been architected to provide hardware level support for SAE AS5643 which reduces host processor burden, specifically for packet encapsulation, data extraction, receive/transmit STOF offsets, etc. As a key example, **FireTrac®** handles AS5643 transmission timing entirely in hardware therefore making it a lot more accurate. It is important to understand that **FireTrac®** is a dedicated and optimized solution for the processing of AS5643 type traffic. Support for this protocol is embedded in the hardware and not just in a software layer (as typically provided with other solutions that rely on COTS OHCI chipsets).

In order to get the best out of the unique feature set of the **FireTrac®** card DapTechnology recommends using the hardware in combination with **FireStack®**, i.e. DapTechnology's home grown software stack. FireStack optimally supports the hardware and firmware layers embedded into FireTrac. As **FireTrac's®** host interface uses FireLink Extended (and not a standard OHCI Link Layer chip) functionality that has been tailored and optimized for the support of the AS5643 standard brings the combination of **FireTrac®** and **FireStack®** to an entirely new level.

A Powerful Mil1394 Solution

FireTrac® provides a very universal approach to dealing with AS5643 type of traffic. It is uniquely suited for SAE AS5643 level Data Extraction and Analysis (RX) but also Data Generation and Device Simulation (TX).

With the **FireTrac®** platform DapTechnology has enabled dedicated implementations needed in the A&D environment. Such application-centric solutions are focused on very specific tasks and, due to their very clearly defined requirements, DapTechnology is able to even further optimize the firmware and software architecture.

Examples for such "customized" solutions are:

- Data Recorders (single/multi-channel, with/without Stealth, ...)
- System Simulators (multi-streams generator, error injection, ...)
- System Monitors (Health, Data Extraction, ...)

FireTrac® uses a combination of 1394 and AS5643 support in hardware, as well as a robust, well-designed 1394 software stack (**FireStack®**) running on a host computer. Interfacing to this stack can be done via an API that offers C/C++ on multiple platforms as well as LabVIEW and Python interfaces on Windows. Currently, DapTechnology supports Windows, VxWorks, Linux, QNX, LabVIEW(RT) and RTX64 platforms.



An essential feature of **FireTrac®** is its adaptable software and firmware layers. In order to be usable in embedded designs having limited resources, great emphasis was given to keep the footprint and host system resource utilization fairly small. And, in order to optimize and streamline performance, the individual features and functions of **FireTrac®** are grouped into so-called Personality Profiles. These profiles may be purchased separately so that the user may configure their system based on individual requirements.

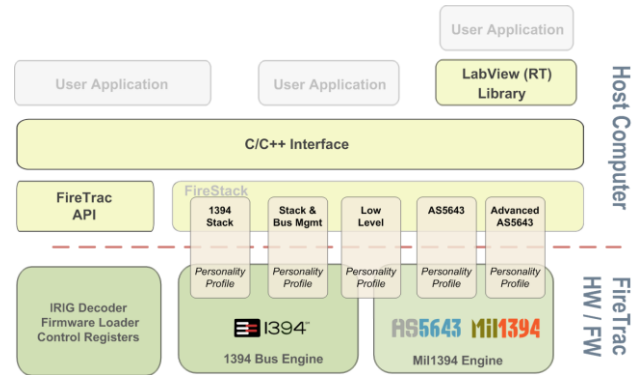

The *Personality Profiles* allow the solution to be adapted for use in embedded systems which typically have limited resources, and/or with powerful host processors that can utilize even the fully featured profile.

The following profiles are available:

- Low-Level API Profile
- 1394 Software Stack Profile
- 1394 Software Stack + Bus Mgmt. Profile
- AS5643 Bus Interface Profile

Functional Modules	Profiles				
	Low-Level API	SW Stack	SW Stack + Bus Mgmt.	AS5643	Advanced AS5643
Single Packet TX / RX	✓	✓	✓	✓	✓
Local PHY Register Access	✓	✓	✓	✓	✓
Bus Reset Detection	✓	✓	✓	✓	✓
Topology Information		✓	✓		
Isochronous Stream RX / TX		✓	✓		
Inbound Transactions		✓	✓		
Outbound Transactions		✓	✓		
TX Jitter Insertion				✓	
TX Error Insertion				pend.	
Cycle Master Capable			✓		
IRM Capable			✓		
Bus Manager Capable			✓		
Automated Data Insertion (HW)					pend.
Automated Data Extraction (HW)					pend.

Application Programming Interface (API)

FireStack® provides an API with multiple levels of abstraction from the 1394 bus that allows for a very "1394-unaware" application programming. Due to the very high degree of abstraction the user does not have to be a 1394 expert for most of the typical 1394 bus control and transaction handling tasks. This high-level API focuses on ease-of-use, low learning curve and streamlined programming.

For very fundamental 1394 bus controls a Low-Level API is available. It can be used for operations on the basic 1394 level. For example, this API allows for remote PHY access, commands, bus optimization, error condition testing, etc. As another example, it provides CRC overwrite functionality in order to simulate erroneous bus signaling as well as other advanced and non-standard features within a SW stack.

AS5643 Personality Profile

The SAE-AS5643 protocol differs from other 1394 protocols because of its stringent timing requirements. Because of potential inaccuracies and unpredictable latencies possible with software implementations, DapTechnology strongly believes that the AS5643 protocol timing is best implemented via a HW extension in the 1394b Link Layer. Therefore, DapTechnology has added the AS5643 protocol timing into **FireLink® Extended** as an integral module. With this HW support FireLink® Extended is easily capable of meeting the AS5643 frame timing requirements and eliminates the need for complicated interrupt schemes or real-time operating systems typically needed to efficiently use the AS5643 protocol.

The **FireStack®** software library contains an AS5643 protocol module that can be used to control the AS5643 hardware of FireLink Extended enabled products (e.g. the FireTrac I/O card). Optimized frame timing can be configured and used for both timed transmission and reception.

Frame Timing: FireStack® is very flexible in the way it handles the timing of Start of Frames. Frame synchronization for AS5643 reception and transmission may be configured as either:

1. Free Running based on an internal clock with a 1us resolution,
 - based on STOF packets on the bus (just any stream packet on a configurable channel),
 - based on an External Sync Input Signal
2. or synchronized to one of the other buses on the same FireTrac.

In addition to acting as a synchronization “slave”, it is also possible for each bus to act as STOF master and output a sync pulse on an External Sync Pin.

Reception: AS5643 reception provides a filtering mechanism and all incoming packets will be run against a comprehensive verification system. Messages can be filtered on channel number, AS5643 message ID or a combination of both.

Transmission: AS5643 Transmission module can be used to control devices that support AS5643 timed transmission in. FireTrac® offers very accurate transmission timing. The following transmission modes are available:

Streaming messages: Allows writing large or small sets of messages to FireStack® and having them transmitted automatically at specified frame offset times. The provided data needs to contain so called frame separator elements to indicate that the following message needs to be transmitted in the next frame.

Repeating messages: Allows setting up a message that will automatically be transmitted each frame by FireTrac hardware. The user will have a pointer to the actual data of the message and is allowed to manipulate the data at any point in time without having to worry about its timed transmission. This is very useful for AS5643 status messages.

Single messages: Allows simply transmitting a message as soon as possible but exactly at the specified frame offset time. Several messages may be handed to the FireStack® for immediate transmission and the FireStack® will then take care of the actual moment of transmission.

STOF Messages: Allows controlling transmission of STOF messages.

XMC Form factor

The selected XMC (PCIe Mezzanine card) form factor offers the best choice and versatility for deploying FireTrac on a wide variety of host platforms. It is compliant with VITA 42.0 XMC base standard which defines physical features that enable a high-speed serial interface between a standard mezzanine card and its carrier. These features include the use of one or more high-speed XMC connectors to carry the signals necessary for such interfaces.

As the XMC form factor becomes more and more accepted across the industry it is now supported by many computing platforms that provide one (or more) XMC connections. From a bus integration perspective XMC cards offer all the benefits of the modern PCIe data interface allowing users to take full advantage of FireTrac’s OHCI compliance.

When needed, DapTechnology pairs the XMC mezzanine card with COTS carrier cards for other PCIe form factors, e.g., PXIe.

DapTechnology has also released a native PMC and PCIe FireTrac products. Check out related offering on www.daptechnology.com.

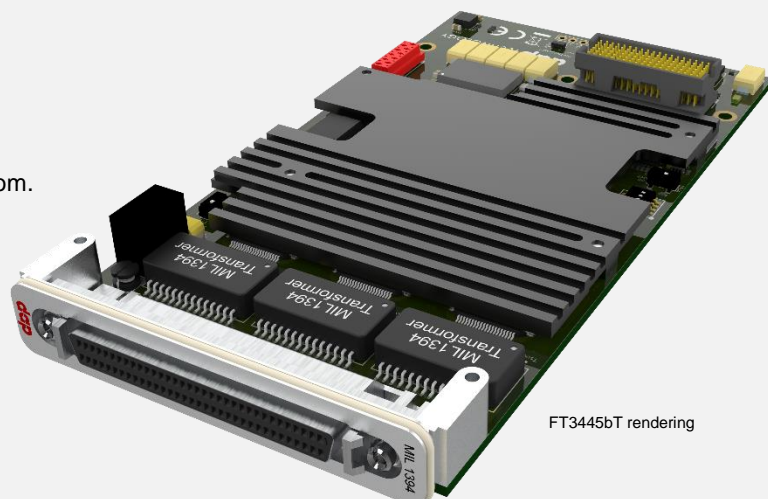

FT3445bT rendering

NETWORK SIMULATION WITH FIRETRAC®

The **FireTrac®** product family offers a large variety of options how these I/O cards can be used to start, expand, and grow a simulation environment for AS5643 devices. While architecturally identical, the different channel numbers allow for a vast variety of configurations. Please note that the configuration scenarios presented below predominantly address triple redundant network systems, yet can relatively simply be adapted for system redundancies lower or higher than three (3).

4-node FireTrac®:

The 4-node version(s) of **FireTrac®** is perfectly suited for use as a CC. As the picture below demonstrates the 4-node architecture is ideal to simulate a 3-branch CC including the interface for the CCDL. Using three **FireTrac®** cards (blue) a full and triple-redundant arrangement for control computers can be realized.

Paired with a triple redundant RN implementation using 3-node **FireTrac®** (displayed in green) one can easily build a minimal yet expandable instantiation of an AS5643 network consisting of CCs with CCDL and RNs.

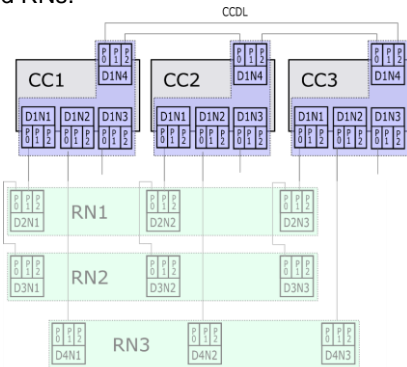

However, the above is only an implementation variant. A 4-node **FireTrac®** can also be used to simulate single branch bus behavior (left and middle) or mixed CC/RN situation in double redundancy (right).

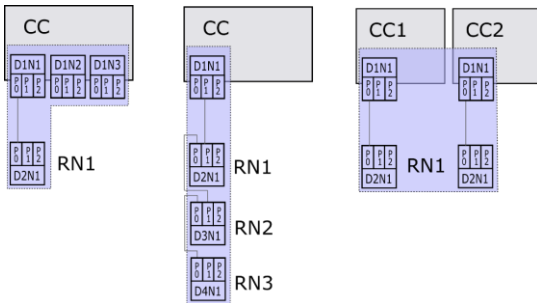

3-node FireTrac®:

The 3-node version(s) of **FireTrac®** is best suited to address triple-redundant and triple-branch architectures when no CCDL is needed. The picture below demonstrates how such a system can be arranged in different RN configurations by using just a few 3-node **FireTrac®** cards (green).

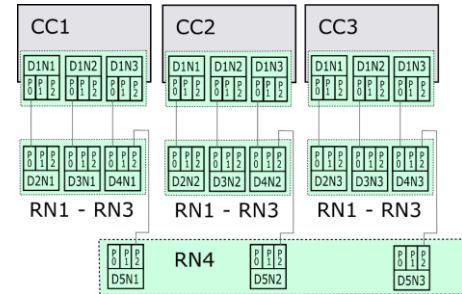

Other variants of how a single 3-node **FireTrac®** card can be used are depicted below. The left shows a CC devices simulating the triple bus interface (3 CC) whereas the right pictures demonstrates a possible single-branch usages model (CC + 2 RNs).

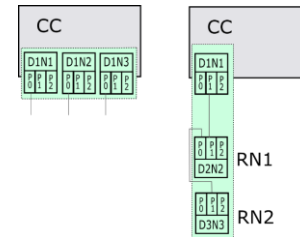

Simulating AS5643 CCs and RNs

SAE AS5643 describes two types of device categories Control Computers (CC) and Remote Nodes (RN) whose functional definitions depend on the assigned tasks with respect to network communication and integrity verifications. Supporting both device types is an integral objective for **FireTrac®** and **FireStack®** and the FireStack API provides feature rich function calls for both categories in parallel. This way the implementer can focus on the AS5643 functional requirements for either CC and RNs. **FireStack®** doesn't put the device in a specific operational mode (either CC or RN) but all related functions and functionalities exist in parallel and – for a multi-node device can be used independently per node. Example applications are (or will be made) available to demonstrate both scenarios.

However, it is also important to understand that **FireTrac®** is not just a dedicated "AS5643 device". It is also a fully compliant IEEE-1394 device. In particular this is important because next to the Async Streams (which are used for the Asynchronous Subscriber Model (ASM)) **FireStack®** also supports Asynchronous as well as Isochronous Messaging. Both are optional for the usage in AS5643. But due to its guaranteed quality-of-service the Asynchronous messaging seems to be the logical choice for Cross-Channel-Data-Link (CCDL) implementations. And video/audio streaming in conjunctions with ASM traffic is seen as a future growth path for future variants of AS5643.

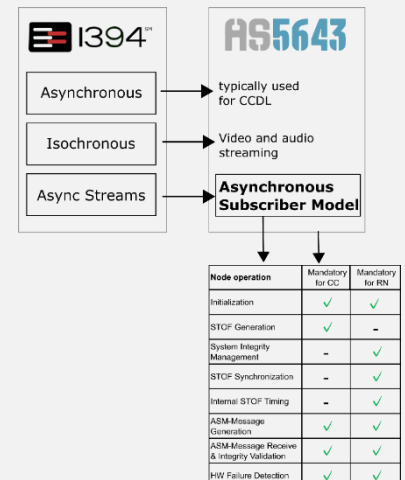

Optimized IEEE-1394 Software Layers

The objective of **FireStack's**® 1394 packet handler is to reduce resource burden when receiving and transmitting 1394 packets. The consistent utilization of zero-copy operations greatly enhances the overall system performance. **FireStack**® provides memory buffers accessible by both the user application and the 1394 Link Layer DMA engine.

For example, when transmitting an asynchronous packet and the user application has filled the memory buffer with the needed packet data, **FireStack**® will hand the buffer directly to the Link Layer for reading the packet into the packet transmission FIFO without having the CPU copy memory to memory.

Likewise, displaying a video stream from an IIDC camera only requires creation of DMA-capable reception buffers for the video frame data and registration of notification upon filling of a complete frame. Once notified the buffers holding the received data can be accessed directly by the video rendering engine in order to move the data to video card memory.

Inbound Transactions:

Inbound Transactions (handling of incoming requests) are defined in two separate methods:

Map Local Memory: The user can "map" a memory buffer to a specific address space. The contents of the memory buffer can be accessed by the user application at any point in time. At the same time when the stack receives a request packet from a remote device it will automatically perform the response operation (read, write or lock) and will send a response packet back to the requester. The user has the option to be notified by the notification callback function when the transaction completes.

Transaction Handler: Similar to the Map Local Memory above the user can "register for" a specific address space instead of "mapping" local memory. When the stack receives a request packet it will call the user-specified handler callback function. The user can then perform any operation within the callback function. Upon returning from the handler callback, the **FireStack**® may transmit a response packet. The notification callback function will be called after completion of the response process.

Outbound Transactions:

This module can be used to perform memory transactions (read, write, lock) on remote nodes. When a memory transaction is initiated **FireStack**® will automatically determine the maximum speed to the destination node by performing the needed PHY remote accesses.

Outbound Transactions can be used in the following ways with respect to result indication: In *Blocking mode* the TX functions will not return until the response packet is received and thus making the code sequential. In contrast to that the *Non-Blocking mode* can be used to initiate a series of "split" transactions i.e. a series of requests that are then followed by the corresponding - but not necessarily sequential - responses.

Isochronous Messaging:

The Isochronous Streaming modules build on the mechanisms for efficient data processing defined by OHCI and provide a flexible and user-friendly API around it. Linked lists of buffers can be setup by the user application and will be automatically processed by the Link Layer DMA engine. Notification mechanisms are available for buffer and/or packet completion.

SCSI2 Connectivity

For this version of **FireTrac**® DapTechnology uses a rather traditional SCSI2 connector. May reason is the form factor and high pin count together with a good signal quality which is so essential for high-speed low-voltage differential data transmissions.

The connector allows to route all bus connections (A0-A2, B0-B2, C0-C2) together with 3 trigger signals as well as the IRIG sync input.



Bus Interconnectivity

In order provide a wide variety of connectivity options – either to additional FireTracs or to other AS5643 equipment, DapTechnology is developing a set of harnesses / interconnectivity options.

For example the 19"-breakout panel as depicted below offers an extremely flexible way to connecting bus devices via 1394b bilingual sockets. Such a "patch"-panel can also be configured with LEMO or 38999 sockets depending on the customer's interconnectivity preferences.



Beside the 19"-panels DapTechnology will offer also a series of cables with a variety of cable types and lengths as well as terminations.



The selected connector/cable choices offer a large variety of options and cannot be displayed in its entirety. Please check on the web for more variants and/or consult with our sales specialists regarding your specific needs, length and connector options.

FT3x45BT FEATURE SUMMARY:

- AS5643 compliant
- IEEE 1394b-2008 compliant
- Supported Speeds*: S100B, S200B, S400B, S800B
*) depending on specific model
- 3 independent 1394 nodes
- Link Layer: FireLink Extended with Mil1394 Extensions
- PHY Layer:
 - FT3445bT: Texas Instruments TSB41BA3DIPFP prepared for and upgradeable to TSB41BA3F-EP
 - FT3845bT: Texas Instruments TSB81BA3EPFP
- 9 active transformer-coupled 1394 ports
- SCSI2 connector 1394, Trigger and IRIG
 - ports A0, A1, A2
 - ports B0, B1, B2
 - ports C0, C1, C2
- Field-upgradable
- PCI Express 2.0 x4
- Sustained multi-bus IEEE-1394 traffic at S400/S800
- IRIG Time Synchronization
 - IRIG-B122 (IEEE1344) modulated
 - IRIG-B002 (IEEE1344) TTL
 - IRIG-B002 (IEEE1344) RS422
- Application Programming Interfaces (API)
 - C/C++
 - Python (on Windows)
- Support for:
 - MS Windows
 - Linux
 - VxWorks
 - LabVIEW (RT)
 - QNX
 - RTX64

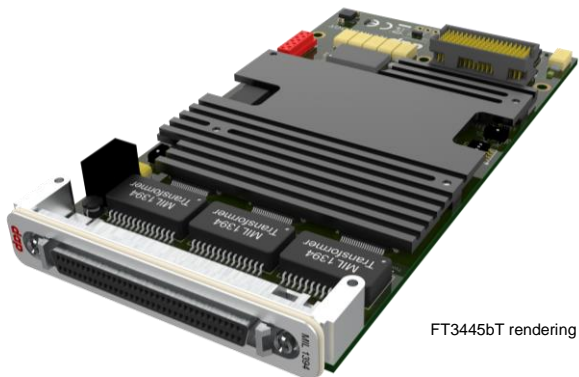

FT3445bT rendering

ARCHITECTURE:

The FireTrac3x45bT was designed using a modern PCI Express based host connectivity approach. Three FireLink 1394b IP cores are connected to a PCI Express controller. This concept allows using the latest PCIe based host connectivity.

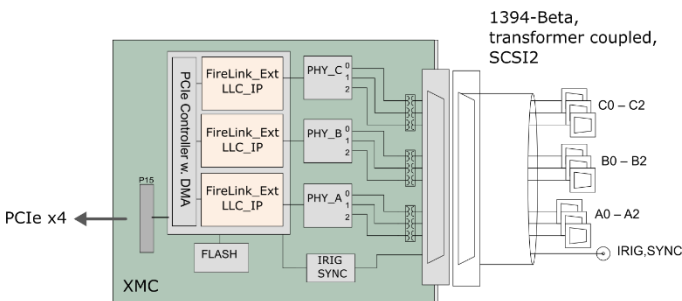

SPECIFICATION:

- Dimensions:** 74x149mm (XMC, single width) as defined by ANSI/VITA 42.0-2016)
- Weight:** 130g
- Operating Range:** -40 - +85 °C, convection cooled
- Power Requirements:** +3.3V, VPWR (+5V or +12V) 7.4 Watts (max.)
- Compliance:** FCC Class A, CE
- Connections:** Primary ANSI/VITA 42.3 connector (P15) for PCI Express interface, Off-board connector (SCSI2) for transformer coupled 1394b ports, IRIG and Sync
- Indicators:** 1x: System OK
- Switches:** 1x: IRIG mode
- Package Content:** FireTrac FT3x45bT XMC card
- Product warranty:** 48 months limited warranty
- Part Number:** FT3445bT-OPT1-OPT2-OPT3-OPT4
FT3445bT1-OPT1-OPT2-OPT3-OPT4
FT3845bT-OPT1-OPT2-OPT3-OPT4

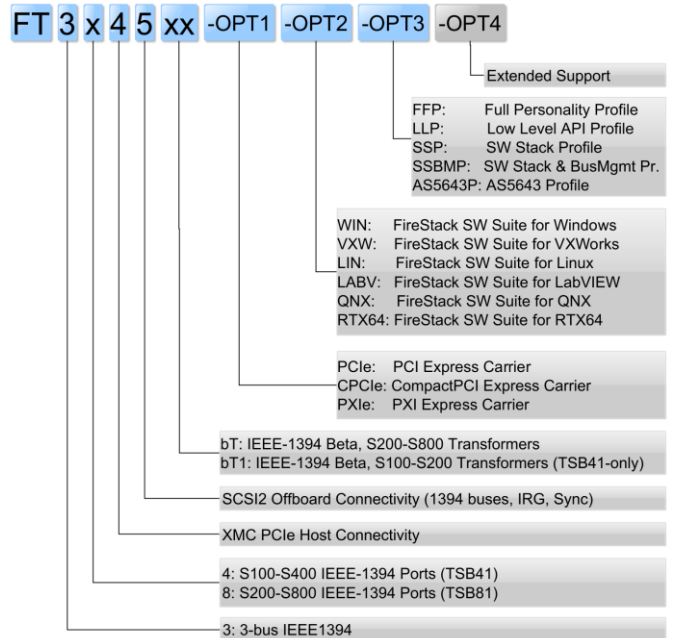

- Accessories:**
 - PMC3CH5F19FP-IS: 3-Channel/9-Port Off-board cable (5 feet) to 19" panel with 1394b(female) (or 38999) connectors and IRIG and Sync Inputs
 - PMC3CH6FBM: 3-Channel/9-Port Off-board cable (6 feet) with bilingual male termination
 - PMC3CH20FNT: 3-Channel/9-Port Off-board cable (20 feet) without termination

Please check our [website](http://www.daptechnology.com) for pictures of cables and accessories and contact Dap directly for other cable requirements

CONTACT INFORMATION:

sales@daptechnology.com

www.daptechnology.com



DapTechnology B.V.
Beatrixstraat 4
7573AA Oldenzaal
The Netherlands
Ph: +31 243 556421

DapUSA, Inc.
780 W San Angelo Street
Gilbert, AZ 85233
United States of America
Ph: (480) 422 1551