



FIRESPY

GEN4 3-BUS SERIES

3422bT
3822bT



PRODUCT OVERVIEW:

The **FireSpy3822bT** and **FireSpy3422bT** bus analyzers are DapTechnology's latest 3-bus IEEE-1394 protocol analyzer. Based on the 4th generation FireSpy analyzer architecture the **FireSpy3x22bT** is the most advanced 1394 test equipment in the market. The **FireSpy3x22bT** in fact combine three FireSpy analyzers in one single instrument. They comprises a significantly more powerful on-board processor and improved connectivity to the host.

The PCIe format takes flexibility to a higher level and addresses the industries growing support for this data interface. This solution enables users to install the FireSpy hardware in any modern PC that has at least one 4-lane (or higher) PCIe slot available. This allows for installation of the FireSpy in developers existing PCs or installing the analyzer in a rugged field service laptop or lunchbox computer.

The **FireSpy3x22bT** have three 1394 nodes connected to three synchronized analysis engines. They are controlled by a dual core ARM processor running at 667MHz. Each node is connected to two 1394 ports. All ports of each node are connected to a 1394 bilingual connector in compliance with the 1394 standard.

The **FireSpy3x22bT** are equipped with 5 GB internal memory and extensive hardware filtering and trigger possibilities. The analyzer can be connected into a host computer using its PCIe interface. On the host you can control the FireSpy using a graphical user interface to analyze and display the bus traffic in a user-friendly way; or you can use the API to program your own control software.

The seamless integration of the SAE AS5643 protocol makes the **FireSpy3x22bT** the preferred tool for many Aerospace & Defense development tasks. DapTechnology has taken considerable efforts to fully support the AS5643 protocol in all major functional areas of the **FireSpy3x22bT** and continuously updates the analyzer functionality according to implementation requirements and ongoing standardization efforts.

Key Features include:

- IEEE 1394b-2008 Beta
- 100 - 800b transfer rates *
- Host connection via PCIe Gen2 4-lane
- On-board dual-core 667ARM processor and programmable logic
- 5 GByte internal memory
- GUI and API for Windows™ Operating Systems
- Powerful software provides:
 - Monitor
 - Recorder
 - Commander
 - Scriptor
 - Generator
 - Filter and Trigger
 - Support for AS5643, IEC61883, AV/C, SBP2, IP1394 and IIDC protocols
- Internal SelfTest
- C/C++ API with wrappers for LabVIEW™

* Depending in the exact model

A COMPLETE SOLUTION:

The **FireDiagnostics Suite** is the most comprehensive collection of 1394 analysis, simulation and interface tools for a wide range of applications. Apart from well established and hardware assisted analyzer tools like Monitor, Recorder, Generator, Commander and Scriptor, the suite also offers a set of software tools designed to integrate the FireSpy products in a wide variety of testing applications, as well as extend customization of its functionality beyond the baseline feature set provided by DapTechnology.

The foundation for all software tools included in the FireDiagnostics Suite is formed by the **Application Programming Interface (API)**. With its interfaces for a wide range of development environments like C/C++ and support for the Windows operating system, the application of FireSpy analyzers is extremely flexible. With its feature-rich function library, all hardware assisted analyzer tools like the Recorder and Generator can be controlled as well as more low-level 1394 bus functions.

The **Recording Viewer** is a standalone application designed to permit trace (recorded data) analysis offline, i.e. without a connected FireSpy. The same comprehensive set of analysis tasks is available but allows for a much smaller PC footprint than having the entire FireSpy application installed.

The **Signal Monitor** is an easy-to-use Mil1394 sub-system monitor and analysis tool that benefits from the hardware-implemented Mil1394 protocol. A customizable set of status signals can be pulled from the bus and displayed in near real-time on a customizable graphical Control Panel. Alarms can be setup to alert the operator of out-of-range values.

Another cornerstone of the FireSpy products is the unparalleled high-level **protocol support**. Besides the hardware-assisted integration of AS5643 the FireSpys also support software-based analysis capabilities for consumer and industrial control based applications. The different protocols require very different implementation details and are therefore very unique in their implementation. However, some key characteristics can be identified and are listed below:

- Nested protocol header decoding
- Protocol payload separation
- Handshake verification
- Logical grouping of related transactions
- Separate protocol view
- Protocol layer CRC and Parity Check
- Customization of display details

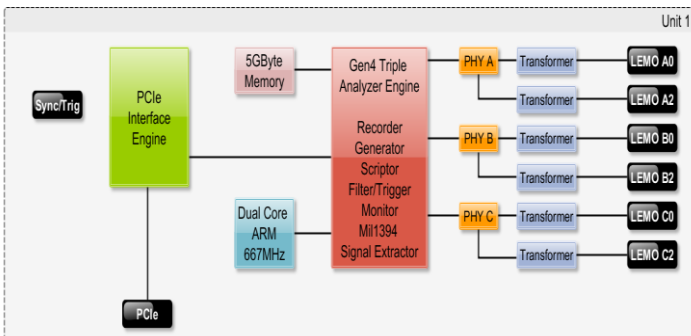

MAIN FEATURE SUMMARY:

GENERAL

- IEEE 1394-2008 Beta compliant
- Supports S100-S800 transfer rates depending on exact model
- Connects to host using PCIe x4 Gen2 interface (4 lane)
- 5 GByte memory for embedded OS and packet and data storage
- Firmware field upgradeable to enable future expansions
- AUX connector for:
 - Trigger input and output functions
 - Recording external event
- GUI and API for Windows™ Operating Systems

MONITOR

- Displays bus activity:
 - isochronous packets
 - all types of asynchronous packets
 - all types of PHY packets
 - all types of acknowledge packets
 - several types of Errors
- Counts packets according to type, speed, ack and error condition
- Counts number of bus resets
- Measurement of bus power voltages (bilingual ports)

RECORDER

- Time stamping of all packets and status events with 10ns resolution
- Packets hidden by slower connections are visible as 'prefix only' packets
- Extensive packet/event filtering/trigger/search capabilities
 - Packet type
 - Transmission speed
 - Boolean combination of 4 programmable packet sets
 - Data payload patterns
 - Error conditions
 - Various status events
 - Graphical Trigger Sequencer
- Adjustable trigger position within programmable record buffer size
- Cyclic pre-trigger buffer management option
- Different kinds of packet display views, including:
 - Time View, displays all packets on a time line, including the prefix
 - Packet View, displays packets as list plus selected packet options
 - Transaction View, displays transactions as list or flow graph
 - Topology View, graphical topology displays as is during recording
 - Protocol View, displays packets decoded to selected protocol
- Precise time measurements
- Marking of individual packets or packet ranges
- Export format for re-generation of packets by Scriptor or API

GENERATOR

- Simultaneous generation of up to 63 iso streams
 - Graphically programming of stream transmit block
 - Data payload import from file
- Generator and Scriptor run simultaneous for stream and asynchronous packet generation
- Special Mil1394 stream generator package (optional)

SCRIPTOR

- Script Editor
 - C-like scripting language
 - Function Library
 - Macros to automatically generate blocks of code
 - Syntax coloring
 - Integrated Debugger
 - Floating point data types
- Data Editor
- Control Panel
 - Graphical display elements for data value representation
 - Ethernet-connected Client Panels for remote data monitoring
- Several Sample Scripts

COMMANDER

- Reading and/or writing of local and reading of remote PHY registers
- Reading and/or writing of remote memory locations (incl. CSR register space)
- Possibility to graphically view the current Topologies
- Sending of user definable packets

SPECIFICATION:

Dimensions:	PCIe x4, card length approx. 205 mm
Operating Range:	0 – 70 C
Power Requirements:	max. 25 W
Compliance:	FCC Class A
Connections:	PCIe x4 Gen2 connector 6x LEMO connectors
Indicators:	-
Switches:	-
Package Content:	FireSpy3x22bT 3x LEMO to Bilingual cables
Product warranty:	48 months limited warranty
Part Number:	FS3822bT or FS3822bTAS5643 (analyzer with AS5643 SW protocol package) FS3422bT or FS3422bTAS5643 (analyzer with AS5643 SW protocol package)

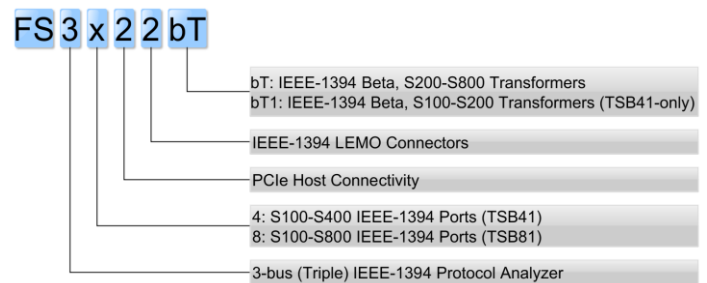

SW Add-on modules:	SBP2 protocol software package IIDC protocol software package AV/C protocol software package IP1394 protocol software package AMI-C protocol software package AS5643 protocol software package
---------------------------	---



CONTACT INFORMATION:

sales@daptechnology.com

www.daptechnology.com

dap TECHNOLOGY • **dap** USA •

DapTechnology B.V.
Beatrixstraat 4
7573AA Oldenzaal
The Netherlands
Ph: +31 541 532941

DapUSA, Inc.
780 W San Angelo Street
Gilbert, AZ 85233
United States of America
Ph: +1 480 422 1551